

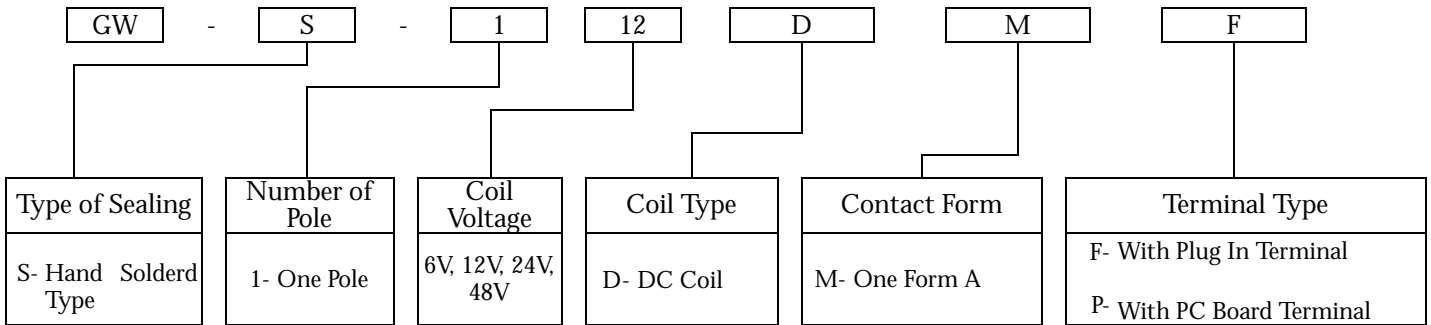

## Coil Specification (at 20°C)

Coil Sensitivity	Nominal Voltage (VDC)	Nominal Current (mA)	Coil Resistance ( $\Omega \pm 10\%$ )	Power Consumption (W)	Pull-In Voltage (VDC)	Drop-Out Voltage (VDC)	Maximum Allowable Voltage (VDC)
GW	6	116.7	51	Abt. 0.7	70% Maximum	10% Minimum	110%
	12	58.3	206				
	24	29.2	823				
	48	14.6	3,232				

## Ordering Information:



## Dimension:

### GW-S-P

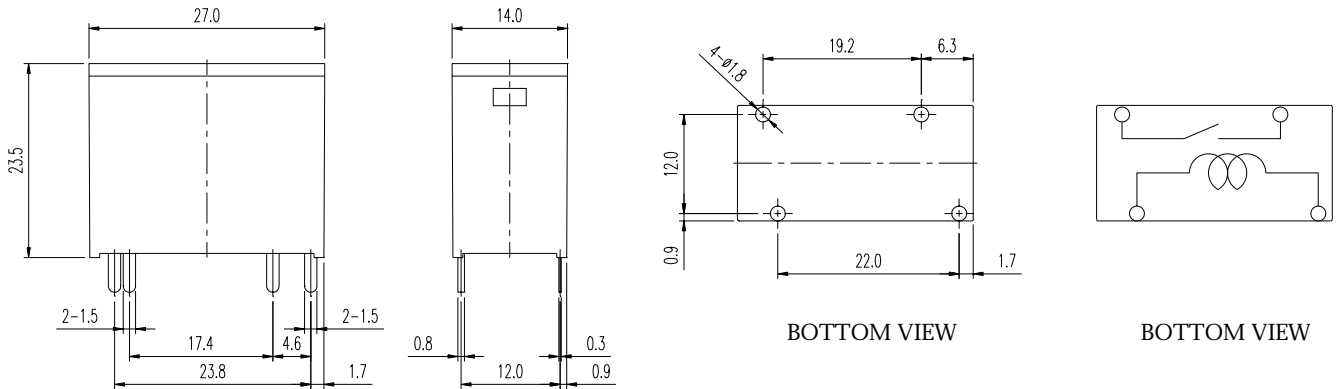

### GW-S-F

